

ANALYSIS OF STRONG RADIATING SHOCKWAVES CONVERGING TO A
CENTER OF SYMMETRY

A. I. Marchenko and V. V. Urban

UDC 533.6.011.72

The asymptotic approximation of a shock front to the center of symmetry ($R \rightarrow 0$) yields unbounded growth of the energy density in the self-similar solution of the problem of a convergent shock [1, 2] considered as an infinitely thin mathematical discontinuity in a perfect gas. In a real medium the shock front has finite thickness and specific structure governed by a set of dissipative physical processes (viscosity, heat conduction, ionization, radiation) [3]. This results in restriction of the cumulation described by the gasdynamic model to a continuous medium in the neighborhood of the focusing, whose minimal size is determined by the gas kinetic path of the particles. Examination of the convergent shock on the basis of the solution of the Boltzmann kinetic equation showed [4] that magnitudes of the macroparameters (density, pressure, temperature, velocity) of the gas take on finite values everywhere. There are a number of papers devoted to studying convergent shocks within the framework of the gasdynamic model of a medium with electron or radiant heat conduction [5, 6], viscosity, heat conduction and energy exchange between ions and electrons in a two-temperature fully ionized plasma [7-10] as well as radiation with a Planck mean absorption coefficient (optically thin case) in a three-temperature approximation taken into account [11]. As is known [3], a large difference exists between the mean free paths of photons and particles of a medium, whereupon the total problem is asymptotically separated into: a) a problem with a shock in a perfect gas with radiation; b) a problem with a shock without radiation with electron heat conduction and energy exchange taken into account in ion and electron collisions, etc. [12]. Continuing the investigations in [5, 11], the problem "a" is examined in this paper when the main process governing the front structure is energy transfer by radiation and the thickness of the jump due to electron heat conduction and other dissipative effects is assumed infinitesimally small. As computations showed, in the convergence of strong radiating shocks of supercritical amplitude the main part of the path of fronts heated by thermal (TW) and shock waves moves according to self-similar power laws analogous to [1, 2]. The transport of energy by radiation not in a state to limit cumulative gas energy density as the front approaches the center of symmetry asymptotically and the finite dimensions of the focusing neighborhood can be determined only when taking account of viscosity in the compression shock. Splitting of the front into two shocks that confirm the results of [11] is detected in an optically thin medium with strongly nonequilibrium radiation. The limit gas density at the time of focusing exceeds the density in a perfect gas multiply [1, 2], however, it remains finite. As the gas optical thickness grows, when radiation becomes almost equilibrium, the nature of the accumulation is modified by going over from perfectly gaseous [1, 2] (finite density and infinite temperature) to heat conducting [5] (infinite density, finite temperature).

1. A gasdynamic flow in a one-temperature approximation was computed by using a known Lagrange finite-difference method with artificial viscosity [13] on nonregular mass meshes with the progressions 1,1, constructed from the central cell to the boundary of the computational domain. Energy transport by radiation was examined under the assumption that radiation scattering, pressure and energy are small, there is hence a local thermodynamic equilibrium in the gas. The main content of the computational method is the following. To determine the mean group intensities $J_{k,j+1}^{\pm}$, relative to the spectrum, that are given at the nodes of the finite-difference mesh $[R_j, R_{j+1}]$, we use equations written for the positive (+) and negative (-) directions of radiation propagation in conformity with the ideas described in [14]

$$S_j J_{hj}^+ = S_j B_{hj} + S_{j-1} (J_{hj-1}^+ - B_{hj-1}) E_{hj-1}^+ - \\ - (B_{hj} S_j - B_{hj-1} S_{j-1}) \Delta_{hj+1/2}^+ + g_{hj}^+ (J_{hj-1}^+ - J_{hj-1}^-),$$

$$S_{j-1}J_{hj-1}^- = S_{j-1}B_{hj-1} + S_j(J_{hj}^- - B_{hj})E_{hj}^- - (B_{hj-1}S_{j-1} - B_{hj}S_j)\Delta_{hj-1/2}^- - g_{hj-1}^-(J_{hj-1}^+ - J_{hj-1}^-). \quad (1.1)$$

Here $S_j = R_j^n \Delta R_j$ are coefficients proportional to the cell surface areas in plane, cylindrical, and spherical cases ($n = 0, 1, 2$); $B_{kj} = \int_{v_k}^{v_{k+1}} B_j dv$; $B = 15\sigma v^3 \exp^{-1}(v/T - 1)/\pi^4$ is

the equilibrium intensity in the k -th spectrum band for the j -th cell ($k = 1, 2, \dots, M$); $E_{kj}^\pm = \exp(-\tau_{kj+1/2}^\pm / \mu_{kj}^\pm)$; $\Delta_{kj+1/2}^\pm = (1 - E_{kj}^\pm) \mu_{kj}^\pm / \tau_{kj+1/2}^\pm$; $\tau_{kj+1/2}^\pm = \kappa_{kj+1/2}^\pm \Delta R_j$ is the optical thickness of the j -th cell, $\kappa_k = \kappa_k^P \times \exp(-\kappa_k^P) + [1 - \exp(-\kappa_k^P)] \kappa_k^R$ (κ_k^P, κ_k^R are Planck and Rosseland mean absorption coefficients in the k -th quantum energy group), μ_{kj}^\pm is the mean cosine of the angle between the direction of radiation propagation and the coordinate R , $g_{kj}^\pm = d_{kj}^\pm \exp(-\tau_{kj+1/2}^\pm) (S_j - S_{j-1})$ is the "sphericity" coefficient [15] obtained by averaging the intensity along rays tangent to the surface of the spherical layer [16]: $d_k^\pm = (J_k)_\mu=0 / (J_k^+ + J_k^-)$. In the cylindrical case d_k^\pm should take into account of radiation entrained along the cylinder and depends on the azimuthal angle [17].

The first three terms in the right side of (1.1) are obtained under the assumption of a linear variation $B_{j+1} = B_j + (B_{j+1} - B_j)(\tau_{j+1} - \tau_j) / \Delta\tau$ [18] on the boundaries of a finite segment $[R_j, R_{j+1}]$ with the optical thickness $\Delta\tau = \kappa_{j+1/2}(R_{j+1} - R_j)$. By passing to the limit $\Delta\tau \rightarrow 0$, $\exp(-\tau/\mu) \approx 1 - \tau/\mu$, $(R + \Delta R)^n \approx R^n + n\Delta R R^{n-1}$ for $\mu^\pm = 1/2$, the relations (1.1) are converted into "forward and back" differential equations in a different geometry $n = 0$ [3], $n = 2$ [19]. In the case of large optical thicknesses the expressions (1.1) correspond to the limit approximation of radiant heat conduction [3] $J_j^\pm = B_j \mp \frac{S_j B_j - S_{j\mp 1} B_{j\mp 1}}{S_j \tau_{j\pm 1/2}^\pm} \mu^\pm$. The boundary conditions for (1.1) are given at the center of symmetry $j = 1$, $J_{k1}^+ = J_{k1}^-$ and on the boundary of the domain under consideration $j = N$, $J_{kN}^- = J_{k0}$ (J_{k0} is the mean intensity of radiation incident from outside). After having solved the $2M \times N$ algebraic equations (1.1) by the stream factorization method [20], the total radiation flux and energy density over the spectrum are found

$$F_j = 2 \sum_{k=1}^M (\mu_{hj}^+ J_{hj}^+ + \mu_{hj}^- J_{hj}^-), \quad U_j = \frac{2}{c} \sum_{k=1}^M (J_{hj}^+ + J_{hj}^-).$$

The problem [21] of the collision of two plane shocks excited by massive pistons in bismuth vapors of different optical thickness was considered to check out the method (1.1). A heated TS layer that expands at supersonic speed occurred ahead of the shock front. In both cases the radiation was substantially nonequilibrium and a fine temperature peak $T_+ = (3 - \gamma)T_f$ appeared at the front (T_f is the temperature behind the front) [3] that is characteristic for shocks of supercritical amplitude. Comparison of computations using (1.1) for $\mu_k^\pm = 1/2$ with the data of [21] showed that the propagation velocities of the TS and the shock are in agreement, where the difference in T_+ was not more than 20% and the discrepancy of the unilateral radiation energy fluxes F^\pm from the front did not exceed several percent at different times.

To test the method in the large optical thickness range, a problem was considered about the radiational cooling of a fixed gas volume for the plane and spherical cases. Computations obtained by using (1.1) completely reproduce the known self-similar solution of this problem $R_f \sim t^{1/(k+2)}$ ($n = 0$) and $R_f \sim t^{1/(3k+2)}$ ($n = 2$) for $k = 6.5$ [3], when the optical thickness of the heated layer behind the TS front grows to $\tau \geq 10$ during cooling. The radiation in a gas with such optical thickness is in equilibrium with a substance $F^+ = \sigma T_f^4$ and reaches the limit of radiant heat conduction.

2. Selecting the boundary conditions governing the excitation of a strong convergent shock with intrinsic radiation during its analysis is apparently not very essential and in absence of radiation arriving from outside ($J_0 = 0$) it is sufficient to satisfy the demand [7] that the piston velocity grow more slowly than in a shock. Here, for instance, the boundary conditions on dissociation of a discontinuity can be used. At a time $t > 0$ let scattering from an external infinite heat gas layer start within a spherical cavity of radius R_0 filled with gas of density ρ_0 at a pressure p_0 . We select the conditions on

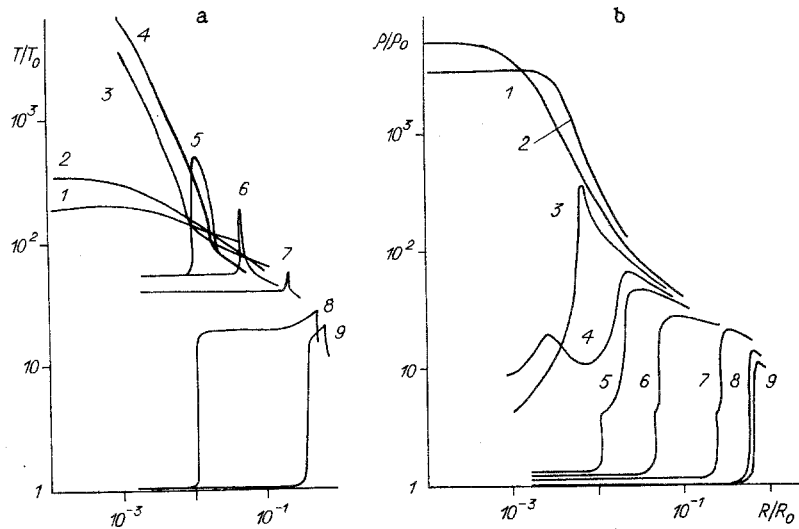

Fig. 1

the discontinuity to be $p/p_0 = 480$ and $\rho/\rho_0 = 8$, which are often utilized for the execution of test computations of strong shocks [22]. We assume the gas behind the contact boundary, the "piston" generating the shock, to be adiabatic and optically transparent, and the influence on the cumulative energy loss due to intrinsic radiation of the shock-compressed layer in the convergent wave is thereby estimated by the upper bound. Let us note that p_0 , ρ_0 can vary in a sufficiently broad band of values and should be such that the heat flux in the gas would be comparable or exceed the hydrodynamic energy flux (in a shock of supercritical amplitude $F > G \cong \rho u^3/2$), but could not be greater than those limits above which taking account of the radiation energy and pressure would be necessary.

As is known [3], the compression shock structure and relaxation zone width in stationary waves of such amplitude are determined by radiation and the difference between the ionic and electronic temperatures, viscosities, and heat conductions can be neglected. Under these conditions, it is natural and convenient to use the approximation of a fully ionized gas for which the thermodynamic relationships and coefficients κ^P , κ^R of brehmstrahlung radiation absorption are well known [3]. Assuming p_0 , ρ_0 constant, the optical characteristics of the gas in the cavity can be varied by changing the charge Z of the nucleus which is in the formula for the temperature and the absorption coefficient and whose range of variation is determined by the condition of a fully ionized medium. The maximal Z can be estimated by the ionization collisional mechanism confirming satisfaction of the condition $I_m/T \approx 0.1$ (I_m is the ionization potential of the last electron from the first atom shell), from which we have $Z_m \approx 30$.

Let us consider the results of computing strong radiating shocks converging to a center of symmetry in a gas of different optical thickness ($Z = 1$ and 30). For the $Z = 1$ modification the change in temperature and density is shown in Figs. 1a and b for wave convergence and reflection at the times $t/t_c = 1.002, 1, 0.997, 0.993, 0.991, 0.976, 0.875, 0.586, 0.468$ (lines 1-9) as a function of the relative path length traversed by the wave. This path is measured from the middle of the first computational cell up to the contact boundary with the external gas exciting the shock. Here t_c is the time of ultimate gas compression at the center (collapse of the shock). It is seen from Fig. 1a that a TS is propagated over the "cold" gas to the center in the initial stage of the motion, behind whose front the gasdynamic motion in the heated layer is weak: the mass flow rate reaches only 10% of the velocity at the front, the density grows 1.3 times, and the pressure is $p/p_0 \approx 100$. The initial optical thickness of the cavity $\tau \sim 10^3$ diminishes to $\tau \sim 1$ at the time $t/t_c = 0.587$ after TS passage; the shock here has almost the critical amplitude. Further shock convergence to the center is accompanied by magnification of the cumulative energy density, whereupon all the gasdynamic quantities grow in the neighborhood of the front. For $t/t_c = 0.875$ (Fig. 1a, curve 7) the shock reaches the supercritical amplitude ($F > G$), the optical thickness ($\tau \approx 0.3$) diminished and the radiation became substantially nonequilibrium ($F \ll \sigma T_f^4$). Let us note that the temperature profiles obtained in the heated layer and on the shock front correspond qualitatively to computations of the initial stage of the convergent

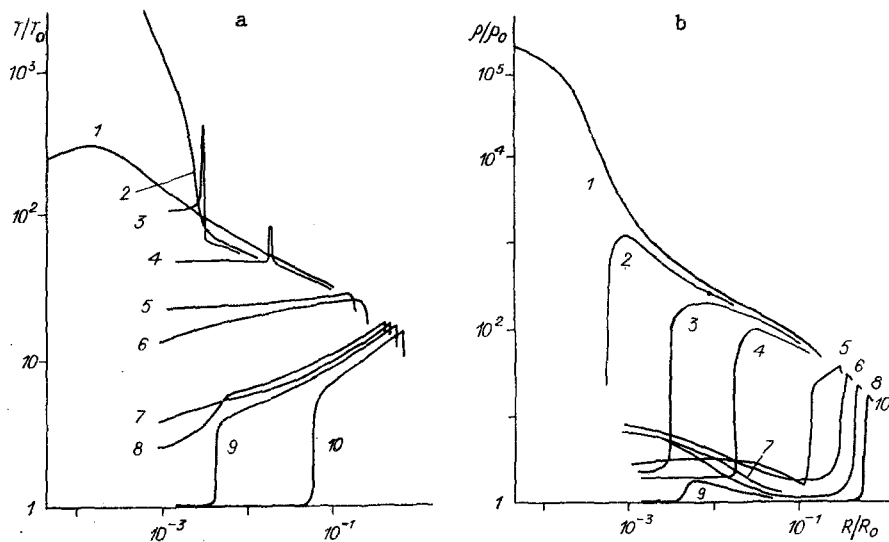

Fig. 2

shock of supercritical amplitude [21, 23]. However, in our case the "light kettle" regime examined in [21, 23] is apparently not realized in full measure since a certain quantity of light energy from the gas behind the shock front can exit through the contact boundary that is transparent according to the formulation taken for the problem, by radiant heat conduction.

As is seen from Fig. 1b, as the wave amplitude grows two density jumps appear all the more clearly on the front: the first is compressive $\rho/\rho_0 = (\gamma + 1)/(\gamma - 1) \approx 4$ ($\gamma = 5/3$) and agrees with the point of the maximum temperature T_+ ; the second ($\rho/\rho_0 \sim 10-100$) corresponds to the inflection point of an exponentially decreasing temperature profile $T = T_f$ (i.e., at the same site where the temperature agrees with $T = T_f$). Up to a certain time there is one maximum of the velocity and pressure on the shock front that are located at the site of the second jump. The cumulative intensity grows sharply as the center of symmetry is approached ($R \leq 0.01 R_0$) so that each of the two density jumps that together form a certain spatial structure starts to move according to its own law. Two maximums corresponding to the mentioned density jumps appear here on the pressure and mass flow rate curves. This is apparently associated with the splitting of the structure into two waves analogous to a "small" and "large" shock detected in [11]. Although the temperature and density profiles in Figs. 1a and b (curve 5) are qualitatively slightly modified after the splitting, the laws of jump motion become substantially different as shown below.*

The time $t/t_c = 0.993$ (curves 4 in Figs. 1a and b) corresponds to focusing of a "small" shock and is characterized by achievement of the first absolute temperature maximum $T/T_0 = 65,000$ and the limit density $\rho_p/\rho_0 = 8.2$ that corresponds with 10% accuracy to the value $\rho_p/\rho_0 = 7.34$ obtained in computations for a perfect gas with $\gamma = 5/3$. As is seen from Fig. 1b, a peak in the maximal density $\rho_m/\rho_0 = 63$, on the right of the limit value, due to the mass precompression of substance, is significantly greater than in the perfect gas with $\gamma = 5/3$ ($\rho_m/\rho_0 = 32.7$ [25]). If we discard the influence of the "large" shock, then it can be concluded that the qualitative pattern at the time of focusing the "small" shock is identical to the pattern of shock collapse in a perfect gas. Curves 1-3 in Figs. 1a and b correspond to stand-off of the "large" shock from the center of symmetry, the time of collapse ($t = t_c$) and the reflection of the "small" shock. The essential singularity of this phase of development of the problem processes under consideration is the attainment of quite high degrees of compression $\rho = 6.47 \cdot 10^3 \rho_0$ as compared with the adiabatic case.

Equilibrium of the radiation with the substance ($F = \sigma T_f^4$) holds in a gas of large optical thickness upon convergence of a strong radiating shock of supercritical amplitude

*Let us note that in a computation with viscosity in [24], the convergent shock started to be slowed down as the temperature rose, but after a certain time again became accelerating although radically weakened. The process appeared as though dissociation of the discontinuity occurred at a certain small radius.

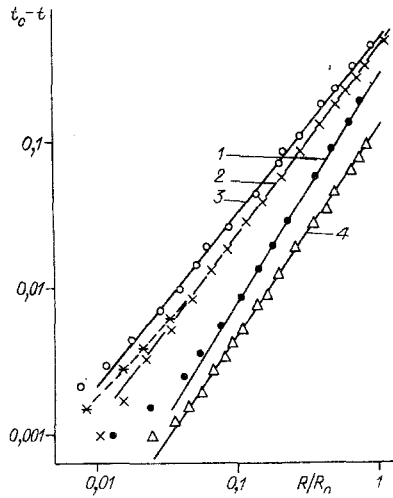

Fig. 3

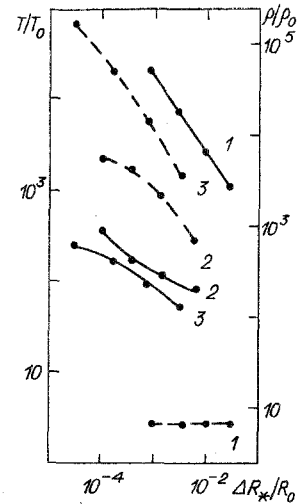

Fig. 4

($F_f > G_f$), and the gasdynamic motion behind the TS front is so intense, as multiple reflection of perturbations from the center of symmetry specifies. Relative temperature and density profiles at the times $t/t_c = 1.000, 0.9996, 0.9990, 0.9934, 0.9240, 0.9020, 0.6276, 0.5875, 0.5536, 0.4534$ (lines 1-10) are shown in Figs. 2a and b for the modification $Z = 30$ as a function of the distance traversed by the converging shock to the center. In this computation the initial optical thickness in the cavity was $\tau \sim 10^4$ and after the first TS traversal diminished in the heated layer to $\tau \sim 100$. For such values of τ the perturbation front is reflected from the center of symmetry and is propagated toward the convergent gasdynamic flow. At the time of TS reflection ($t/t_c = 0.587$, Figs. 2a and b), gas compression at the center reaches $\rho/\rho_0 = 6.6$ while the temperature almost does not change. Only repeated TS passage from the shock front to the center ($t/t_c = 0.902$) increases the temperature almost 5 times in the heated layer, where the gas compression diminishes to $\rho/\rho_0 \approx 2-4$. A new reflection of the flux from the center would agree in time with the approach of the shock, whose amplitude and flux F^- from the front start to grow sharply. The optical thickness ahead of the shock front here diminishes to $\tau \approx 2$ and the heated layer becomes isothermal. From the time $t/t_c \approx 0.9530$ the radiation starts to become nonequilibrium in nature ($\eta = T_f/(F_f/\sigma)^{1/4} > 1$), but until the shock arrival in the first cell from the center η does not exceed 10. Splitting of the convergent wave structure is not detected in this modification. For comparison, we mention that the degree of nonequilibrium η was above 300 for the $Z = 1$ modification at the time $t/t_c = 0.9910$ that is near to the time of splitting.

Trajectories of the TS fronts are presented in Fig. 3 for the considered modifications of the shock focusing computations (for $Z = 1$ and 30 they agree, line 1) and the shock ($Z = 1, 30$, lines 2 and 3). Line 4 is the adiabatic shock converging in a perfect gas with $\gamma = 5/3$. The dashes depict the trajectory of the "large" shock after the splitting. As is seen, the fronts of the first TS up to $R/R_0 < 0.1$ and the shock fronts up to the arrival at the first cell of the computational mesh from the center move according to the law $R \sim t^{-(k-1)}$. Strongly radiating shocks stand off from the adiabatic; however, as analysis of the computational data shows, they have identical self-similar dependence of the gasdynamic quantities at the front: $p \sim T \sim R^{-2(k-1)}$, $u \sim R^{-(k-1)}$. In a perfect gas ($\gamma = 5/3$) $k = 1.453$ [25], the numerical values are $k = 1.25$ and 1.3 , respectively, for $Z = 30$ and 1. The last quantity agrees with that presented in [11], however, it is obtained here without taking account of electron-ion viscosity and heat conduction, the difference in the temperatures of these components and their mutual energy exchange.

Bounded values dependent on assignment of the computational viscosity are always obtained in the numerical computations in the neighborhood of the focusing of any shocks. The limit temperature and pressure in a perfect gas grow according to a self-similar law $T_p \sim p_p \sim \Delta R_*^{-2(k-1)}$ as the detail in describing the neighborhood of the center of symmetry increases (the size and number of the computational cells), where ΔR_* is the minimal dimension at the time of compression of the first cell of the computational mesh from the center, while the density always remains constant. As the focus in neighborhood diminishes

in strongly radiating shocks, the limit parameters vary, firstly, not according to a self-similar law (apparently this is due to the general non-self-similarity of the problem of a convergent radiating shock) and, secondly, depend on the optical thickness of the gasdynamic flow. A multiple increase in the limit compression $\rho_p/\rho_0 \sim 10^2-10^4$ accompanying the radiation cooling of the substance holds here in a radiating gas. Displayed in Fig. 4 are dependences of the temperature (solid lines) and density (dashes) for different computed sizes of the neighborhood of the center of symmetry at the time of shock collapse for a perfect gas (line 1) and the modifications with $Z = 1$ and 30 (lines 2 and 3). As follows from the results presented, the cumulative energy density in the gas grows without limit in all cases and is not eliminated by energy transport by radiation; however, the nature of the accumulation in a perfect gas (finite density, infinite temperature) is modified in an optically thick medium (infinite density, finite temperature), which corresponds to the known deduction [5] obtained in the radiant heat conduction approximation.

In discussing results of computations of convergent shocks by finite-difference methods it is impossible not to examine the question of the correctness and the limits of applicability of the solutions obtained. The necessary condition for the correctness of a numerical solution in a perfect gas is its agreement with the self-similar solution (as was also mentioned in [9]). However, such a condition cannot be sufficient since conformity to the self-similar law is observed only on a bounded segment of the path at a certain distance from the center of symmetry. Consequently, the behavior of the numerical solution must be analyzed as the detail in the description of the focusing neighborhood increases. A study performed for the problem of a convergent shock in a perfect gas showed that a finite size of the neighborhood of the center of symmetry $R_* \geq \Delta R_*/R_0$ can be found by numerical means because of the change in the quantity of cells, such that the distributions of all the gasdynamic quantities would agree with a certain accuracy for a computation with a diminished central cell of the difference mesh ΔR_1 for $R/R_0 > R_*$ at each time in both computations. By successive diminution of ΔR_1 (with the increase in the total number of cells) convergence of the profiles of the gasdynamic quantities can be achieved to any given accuracy. This is due to the fact that the total energy $E \sim R^{5-2k}$ in the self-similar solution diminishes so strongly at the shock front as $R \rightarrow 0$ that no influence is exerted on the gasdynamic parameters of convergent and divergent (after reflection) flows. A numerical solution successfully "avoids" difficulties at the center of symmetry by going from one branch to another of the asymptotic for $R/R_0 > R_*$.

An analogous dependence of the total energy and the convergence of the profiles of the gasdynamic quantities hold in the analysis of strong radiating shock focusing. For instance, as the number of cells grows from 50 to 70, 100, and 130 in the cavity with a simultaneous diminution of each preceding central cell size by three times, satisfactory agreement of the profiles is achieved on a 100 cell mesh. In these modifications the total energy de-excited with respect to time, referred to the total gas energy in the cavity (the integral is taken from $R = 0$ to the contact boundary), varied as follows at the time of collapse: 0.333, 0.317, 0.314, 0.313 ($Z = 1$); 0.398, 0.386, 0.383, ($Z = 30$).

On the basis of the above, the deduction can be made that the sufficient condition for correctness of the numerical solution is satisfied only outside a certain neighborhood R_* of shock focusing. In the gasdynamic model for describing the medium the specific value of R_* depends on energy dissipation mechanisms in the shock front being taken into account in the problem, (cases "a", "b", etc. [12]). The minimal focusing neighborhood will apparently be achieved when taking account of viscous effect in the compression shock. In fully ionized plasma this scale is commensurate with the Coulomb ion path length. A final determination of the parameters for a cumulative convergent shock is possible only in a gaskinetic model.

The authors are grateful to M. V. Babykin and L. I. Rudakov for attention to the research and discussions, and to V. S. Imshennik for a number of valuable remarks.

LITERATURE CITED

1. G. Guderley, "Starke kugelige und zylindrische Verdichtungsstosse in der Nahe des Kugelmittelpunktes bzw. der Zylinderachse," Luftfahrtforschung, 19, No. 9 (1942).
2. K. P. Stanyukovich, Unsteady Motion of a Continuous Medium [in Russian], Nauka, Moscow (1971).
3. Ya. B. Zel'dovich and Yu. P. Raizer, Physics of Shocks and High-Temperature Hydrodynamic Phenomena [in Russian], Fizmatgiz (1963).

4. I. I. Kudish and V. A. Rykov, "On the convergence to a center and reflection of a spherical wave in a gas," *Zh. Vychisl. Mat. Mat. Fiz.*, 16, No. 5, (1976).
5. E. I. Zababakhin and V. A. Simonenko, "Convergent shock in a heat conducting gas," *Prikl. Mat. Mekh.*, 29, No. 2 (1965).
6. A. A. Makhmudov, "Shock convergence to a center of symmetry and its reflection in a heat-conducting gas," *Uchen Zap. TsAGI*, 11, No. 4 (1980).
7. V. F. D'yachenko and V. S. Imshennik, "Convergent cylindrical shock in a plasma with structure of the front taken into account," *Zh. Vychisl. Mat. Mat. Fiz.*, 3, No. 5 (1963).
8. V. F. D'yachenko and V. S. Imshennik, "On a convergent cylindrically symmetric shock in the presence of dissipative effects," *Prikl. Mat. Mekh.*, 29, No. 6 (1965).
9. E. A. Berchenko and V. P. Korobeinikov, "Numerical investigation of convergent shocks," *Dokl. Akad. Nauk SSSR*, 230, No. 6 (1976).
10. V. S. Imshennik, "Cumulative convergent shocks with dissipative processes taken into account," *Zh. Prikl. Mekh. Tekh. Fiz.*, No. 6 (1980).
11. N. A. Bardin, "Shock focusing in a three-temperature plasma," *Zh. Prikl. Mekh. Tekh. Fiz.*, No. 4 (1984).
12. V. S. Imshennik, "Shock structure in a dense high-temperature plasma," *Fiz. Plasmy*, 1, No. 2 (1975).
13. R. D. Richtmyer and K. W. Morton, *Difference Methods for Initial-Value Problems*, 2nd Ed., Wiley-Interscience (1967).
14. M. A. El'yashevich, G. S. Romanov, and Yu. A. Stankevich, "Computation of parameters of light-erosive plasma torches with spectral dependences of their radiative characteristics taken into account," *Proc. 4th All-Union Conf., "Radiating Gas Dynamics"* [in Russian], Vol. 1, Moscow State Univ. (1981).
15. N. V. Nemchinov, "On averaged radiation transport equations and their utilization in the solution of gasdynamic problems," *Prikl. Mat. Mekh.*, 34, No. 4 (1970).
16. B. N. Bazylev and G. S. Romanov, "Numerical solution of the spectral radiation-gasdynamic problem of radiant cooling of a spherical plasma volume with nonstationarity of the radiation transport process taken into account," *Inzh.-Fiz. Zh.*, 31, No. 2 (1981).
17. A. D. Rekin, "Radiation transport equations in the Shuster-Schwartzchild approximation for problems with spherical and cylindrical symmetry," *Teplofiz. Vys. Temp.*, 16, No. 4 (1978).
18. A. P. Golub', T. B. Malyavina, and I. V. Nemchinov, "On averaging of the radiation transport equations for the solution of two-dimensional radiation-gasdynamic problems," *Inzh.-Fiz. Zh.*, 45, No. 4 (1983).
19. G. S. Romanov, B. N. Bazylev, and K. L. Stepanov, "Radiant cooling of a spherical cloud of fully ionized gas dissipating in a vacuum," *Dokl. Akad. Nauk BSSR*, 22, No. 2 (1978).
20. A. A. Samarskii and Yu. P. Popov, *Difference Methods of Solving Gas Dynamics Problems* [in Russian], Nauka, Moscow (1980).
21. I. V. Nemchinov, I. A. Trubetskaya, and V. V. Shuvalov, "Intensively radiating supercritical shocks," *Zh. Prikl. Mekh. Tekh. Fiz.*, No. 2 (1986).
22. A. M. Zhmakin and A. A. Fursenko, "On a monotonic difference scheme of through computation," *Zh. Vychisl. Mat. Mat. Fiz.*, 20, No. 4 (1980).
23. I. V. Nemchinov and V. V. Shuvalov, "On radiation of convergent shocks," *Zh. Tekh. Fiz.*, 55, No. 10 (1985).
24. V. F. D'yachenko and V. S. Imshennik, "On a magnetohydrodynamic theory of the pinch-effect in a high-temperature dense plasma," *Voprosy Teorii Plazmy* [in Russian], No. 5, Atomizdat, Moscow (1967).
25. L. D. Landau and E. M. Lifshits, *Hydrodynamics* [in Russian], Nauka, Moscow (1986).